

# MODEL 20

## MAGNETOMETER SENSOR

### FEATURES

- High accuracy over an extended temperature range
- High shock and vibration tolerance
- Low noise level
- Both analog and calibrated digital output available
- Rugged hermetically sealed packaging
- Standard sizes and miniaturized sized units available

### APPLICATIONS

- Navigation systems
- Inertial guidance systems
- Magnetic anomaly detection
- Electronic compass applications
- Measurement of the Earth's magnetic field

The technology employed in the Applied Physics Systems magnetometer product line is generally referred to as a fluxgate technology. Fluxgate magnetometers employing saturable cores driven by a high frequency carrier parametrically up convert low frequency magnetic field variations to sidebands on the carrier. This approach produces a low noise, high accuracy sensor; noise level of 0.2 nanotesla RMS/ $\sqrt{\text{Hz}}$  and an offset drift of less than 5 nanotesla/ $^{\circ}\text{C}$  are specifications for the Model 20 fluxgate magnetometer system.

The Model 20 system outputs include 3-axis analog outputs plus a serial digital interface.

It produces a very linear response over the entire dynamic range of the system.

The outstanding performance parameters of these systems are the bias and scale factor stability over temperature and time.



As an option, internal compensation of the system bias and scale factor can be ordered. This internal compensation increases the system accuracy over temperature and eliminates the need for the system user to perform external temperature compensation.

The Earth's magnetic field magnitude is roughly 0.5 Gauss and the Model 20 can be used to measure this with great accuracy. When used as a magnetic compass, the magnetometers can be used to determine the azimuth angle of the system to which they are mounted. Specific compass applications include use in horizontal directional drilling and logging systems and use in direction finding equipment. The low noise level of the magnetometers enables magnetic anomaly detection in applications such as locating buried ordinance.

## ELECTRICAL

Input Voltage Range	+ 5 V ± 0.1 V
Current	35 mA
Polarity	Positive output for all axes results when field is applied in positive X, Y, and Z directions
Analog to Digital	16 bit
Operating Temperature Range	-20°C to +85°C

## PERFORMANCE

Analog Dynamic Range	1.2x10 <sup>-4</sup> Tesla (1.2 Gauss)
Noise Level (analog)	0.2 nT RMS/√Hz (.0002 mG RMS/√Hz)
Linearity	0.1% Full Scale
Frequency Response	DC to 300 Hz (-3 dB)
Digital LSB Resolution	3.7 nT (37 μG)
SCALE FACTOR	
Analog Scale Factor at 25°C	3 V/100 μT (3V/G)
Temperature Sensitivity Scale Factor	< ±5 nT/°C (±.005 mG/°C)
BIAS	
Initial Bias at 25°C	< ±100 nT (< ±1 mGauss)
Temperature Sensitivity of Bias	< ±5 nT/°C (±.005 mGauss/°C)
Axis Alignment	< ±1°

## PHYSICAL

Cylindrical diameter	0.785" (19.939 mm)
Height	1.430" (36.322 mm)
Weight	30 g
Packaging	Hermetically sealed nonmagnetic nitronic 50 enclosure

## ELECTRICAL CONNECTIONS

PIN	FUNCTION
1	Z Output
2	Serial In (TTL)
3	+ Voltage In (+5 V)
4	No Connection
5	Serial Output (TTL)
6	Ground
7	X OUTPUT
8	Y Output

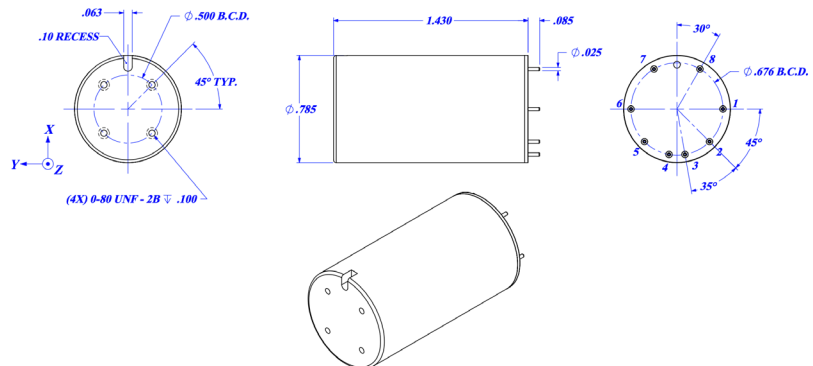

Specifications are subject to change without notice.